

Fits following cars:
 Golf / Jetta 3 VR6, 2.0, Syncro
 1991-1999
 Corrado VR6

VW Golf3 / Jetta3 / Corrado Transmission mount

Fitting notes:

(installation of this mount is not straightforward. There are several ways of installtion.

You can either loosen off all 3 engine mounts and hoist the motor, lean it to the side allowing access to transmission mount. The drive axl may need to be disconnected from the gearbox flange to allow adequate access to replace the mount.

An alternative method may include removing the cast bracket arm off the transmission.)

- 1) Remove top bolt completely from original mount.
- 2) Replave mount
- 3) Secure new mount to torques as shown below.
- 4) Engine all engine monuts are torqued before driving car.

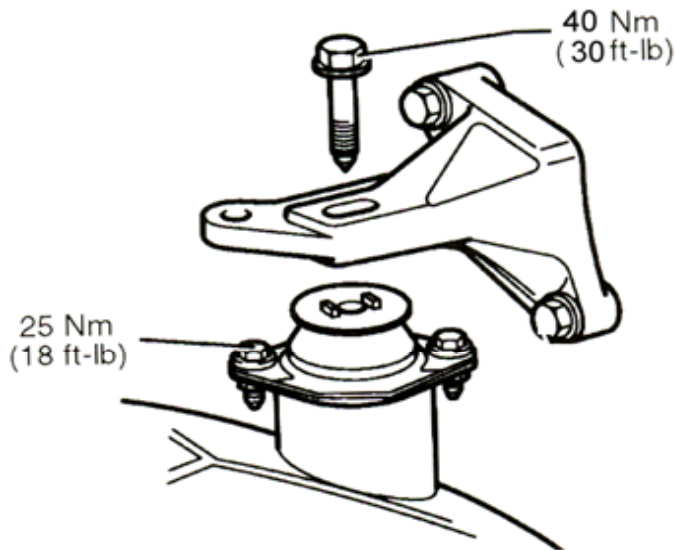

Warranty: 12 months or 12,000 miles whichever occurs sooner on defective parts only. No liability is accepted for misused or misfitted parts. For off-road use only. If in doubt do not fit part and consult retailer.

	MANF BY	Zurich Engineering, Inc. www.vf-engineering.com
	15 Jun 04	
TOLERANCE		VF PART
DRAWN	MFG ENG	

THE PRODUCT AND INFORMATION SUPPLIED IS THE SOLE PROPERTY OF ZURICH ENGINEERING, INC. ANY REPRODUCTION IN PART OR WHOLE WITHOUT THE WRITTEN PERMISSION OF ZURICH ENGINEERING, INC. IS PROHIBITED.