

Fits following cars:
 Golf / Jetta 3 VR6, 2.0, Syncro
 1991-1999
 Corrado VR6

VW Golf3 / Jetta3 / Corrado Rear Engine mount.

Fitting notes:

- 1) Loosen off all 3 engine mounts
- 2) Remove top bolt completely from original mount. Raise engine with hoist or Jack.
- 3) Remove 2 small bolts holding original mount cup to subframe.
- 4) Remove mount completely from car and dis-assemble mount by bending back 2 of the 4 tabs holding the assembly together.
- 5) The lower soft-rubber do-nut is no longer used. Replace top half of mount with new VF mount and secure in cup with washer provided and nut supplied- tighten nut to 33-35 Nm.
- 6) Fit complete mount assembly back in place on the subframe and tighten all 3 bolts as shown below
- 7) Secure O2 sensor wiring bracket aside with zip-tie supplied.
- 8) Torque all engine mounts before driving car.

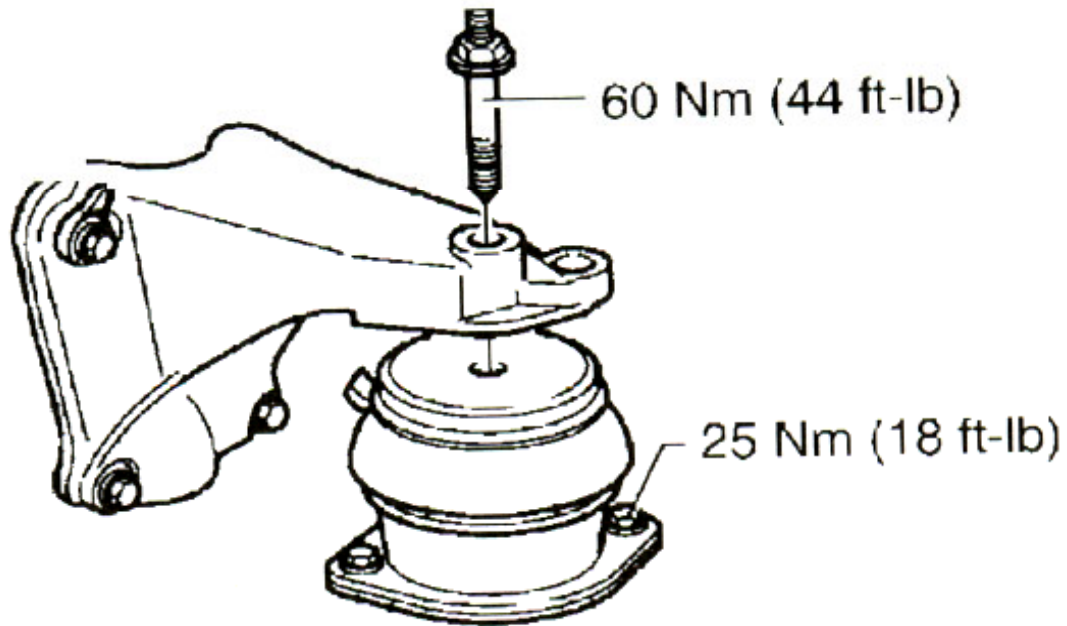

Warranty: 12 months or 12,000 miles whichever occurs sooner on defective parts only. No liability is accepted for misused or misfitted parts. For off-road use only. If in doubt do not fit part and consult retailer.

	MANF BY	Zurich Engineering, Inc. www.vf-engineering.com
	15 Jun 04	
TOLERANCE		VF PART
DRAWN	MFG ENG	