

FITS FOLLOWING VEHICLES: \_\_\_\_\_ Golf  
 MK3 VR6/GTI 91>98  
 Vento VR6 95>98  
 Jetta MK3 VR6/GLX 91>98  
 Corrado VR6 2.8>2.9  
 Passat B4 VR6/GLX  
 Golf MK3 VR6 Syncro 2.9

## Front Engine mount

### Fitting Instructions:

- 1) Remove front engine mount bolt from top.
- 2) Remove front engine mount lower cup and bush.
- 3) Raise engine with support and completely remove stock engine mount.
- 4) Fit VF-Engineering mount into front cross member cup (rotation is not critical) with red bush showing upwards.
- 5) Gradually lower engine, ensuring engine bracket hole is aligned with the mount bolt.
- 6) From under the mount: Place washer over stud and tighten down with nut provided to spec below.
- 7) From on top of the mount: Tighten down nut provided to spec below.

**Secure TOP M10 Flange Nyloc Nut to 40-42 Nm**

**Secure LOWER M10 Flange Nyloc Nut to 33-35 Nm**

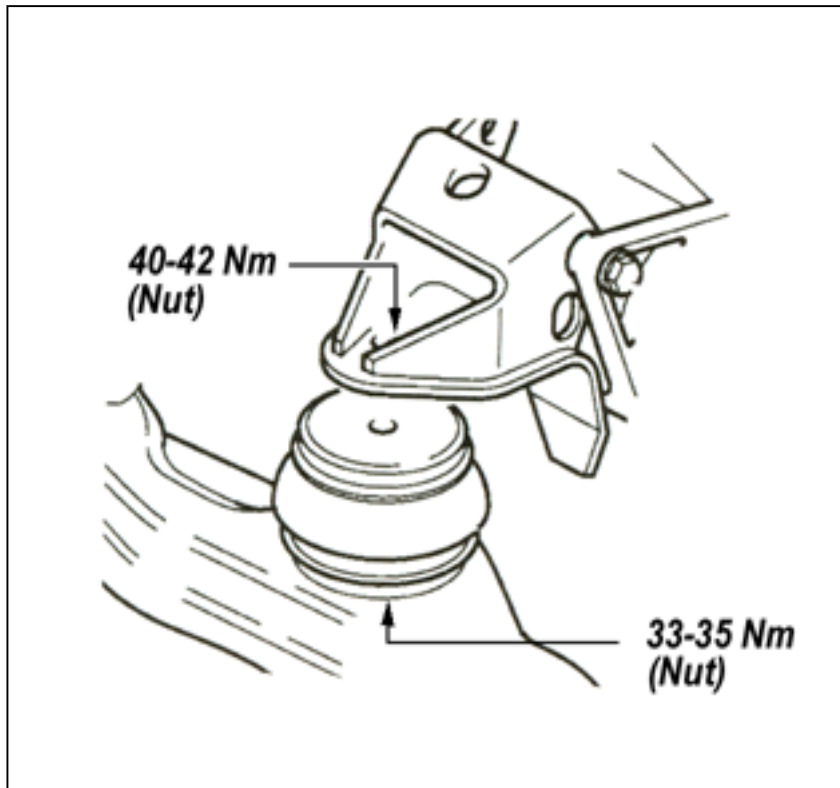

**Warranty:** 12 months unlimited miles on mount **only**.  
 Warranty is invalid if part is mis-used, mis-fitment or altered in any way.

ALWAYS DOUBLE CHECK FITMENT AND MAINTAIN PRODUCT AT REGULAR INTERVALS	CHECKED	<b>VF-Engineering,</b>  <a href="http://www.vf-engineering.com">www.vf-engineering.com</a>
	REGULARLY CHECK THE WEBSITE FOR LATEST PRODUCT UPDATES AND CHANGES.	
TOLERANCE		VW MK3 FRONT ENGINE MOUNT
DRAWN	MFG ENG	
QUAL ENG	FINISH	REVISION: 30-MAY-03

THE PRODUCT AND INFORMATION SUPPLIED IS THE SOLE PROPERTY OF VF-ENGINEERING. ANY REPRODUCTION IN PART OR WHOLE WITHOUT THE WRITTEN PERMISSION OF VF-ENGINEERING IS PROHIBITED.